



BMT Series Hydraulic Motors

BMT series motor adapt the advanced Geroler gear set design with disc distribution flow and high pressure. The unit can be supplied the individual variant in operating multifunction in accordance with requirement of applications.

Characteristic features:

- * Advanced manufacturing devices for the Geroler gear set, which use low pressure of start-up, provide smooth and reliable operation and high efficiency.
- * The output shaft adapts in tapered roller bearings that permit high axial and radial forces. Can offer capacities of high pressure and high torque in the wide of applications.
- * Advanced design in disc distribution flow, which can automatically compensate in operating with high volume efficiency and long life, provide smooth and reliable operation.

Main Specifications

Type		BMT 160	BMT 200	BMT 230	BMT 250	BMT 315	BMT 400	BMT 500	BMT 630	BMT 800
Geometric displacement (cm ³ /rev.)		161.1	201.4	232.5	251.8	326.3	410.9	523.6	629.1	801.8
Max. speed (rpm)	cont.	625	625	536	500	380	305	240	196	154
	int.	780	750	643	600	460	365	285	233	185
Max. torque (N•m)	cont.	470	590	670	730	950	1080	1220	1318	1464
	int.	560	710	821	880	1140	1260	1370	1498	1520
	peak	669	838	958	1036	1346.3	1450.3	1643.8	1618.8	1665
Max. output (kW)	cont.	27.7	34.9	34.7	34.5	34.9	31.2	28.8	25.3	22.2
	int.	32	40	40	40	40	35	35	27.5	26.8
Max. pressure drop (MPa)	cont.	20	20	20	20	20	18	16	14	12.5
	int.	24	24	24	24	24	21	18	16	13
	peak	28	28	28	28	28	24	21	19	16
Max. flow (L/min)	cont.	100	125	125	125	125	125	125	125	125
	int.	125	150	150	150	150	150	150	150	150
Max. inlet pressure (MPa)	cont.	21	21	21	21	21	21	21	21	21
	int.	25	25	25	25	25	25	25	25	25
	peak	30	30	30	30	30	30	30	30	30
Weight (kg)		19.5	20	20.4	20.5	21	22	23	24	25

* Continuous pressure: Max. value of operating motor continuously.

* Intermittent pressure: Max. value of operating motor in 6 seconds per minute.

* Peak pressure: Max. value of operating motor in 0.6 second per minute.

When crossing:

Eaton Char-Lynn 4000 Series:
(109-, 112-)

Danfoss OMT Series:

Danfoss OMTS Series:

M+S MLHT Series:

Consider:

Anfield BMTE models

Anfield BMT models
(the BMTY is the improved model of the BMT)

Anfield BMTS models

Anfield BMT models
(the BMTY is the improved model of the BMT)



Performance Data

BMT 160 [161.1cm³/rev.]

Pressure (MPa)

		Max.cont.				Max.int.		
		4	8	10	12	16	20	24
Flow (L/min)	10	88 60	176 59	228 58	275 56	361 54	447 50	535 44
	20	89 121	181 120	234 117	277 114	372 109	459 103	557 95
Max.cont.	40	91 249	180 246	235 243	277 236	381 230	471 223	573 212
	60	82 371	178 367	235 362	277 356	381 349	470 340	572 330
Max.int.	80	78 492	173 489	229 485	276 478	379 470	466 462	567 447
	100	70 614	160 611	218 606	269 598	370 590	455 582	558 570
	125	58 770	148 764	211 758	261 750	359 741	448 731	552 715

BMT 200 [201.4cm³/rev.]

Pressure (MPa)

		Max.cont.				Max.int.		
		4	8	10	12	16	20	24
Flow (L/min)	10	124 47	233 46	289 45	340 42	454 39	560 37	669 33
	20	125 95	239 94	298 92	347 90	468 87	576 84	696 75
Max.cont.	40	120 195	241 193	296 191	352 187	475 183	589 178	716 167
	60	116 297	237 295	295 292	352 287	478 282	589 276	718 263
Max.int.	80	108 395	231 393	289 389	350 384	474 377	586 370	716 359
	100	99 493	227 490	286 486	344 482	471 475	580 467	712 460
	125	84 615	208 611	276 607	333 602	459 595	566 588	697 572
	150	70 743	194 740	260 735	324 727	447 717	554 706	682 682

BMT 250 [251.8cm³/rev.]

Pressure (MPa)

		Max.cont.				Max.int.		
		4	8	10	12	16	20	24
Flow (L/min)	10	138 38	286 38	355 37	419 36	559 34	689 32	824 31
	20	143 76	296 75	364 74	432 72	580 70	708 67	853 62
Max.cont.	40	139 156	301 154	372 152	440 149	593 146	723 142	884 134
	60	132 237	294 236	372 233	441 229	592 224	727 219	888 207
Max.int.	80	128 317	283 316	364 314	433 308	587 303	721 299	887 284
	100	126 396	282 394	355 391	427 387	582 381	716 373	879 359
	125	116 495	260 492	340 488	414 483	568 476	703 469	864 454
	150	88 592	242 589	320 585	397 580	552 572	686 565	847 545

BMT 315 [326.3cm³/rev.]

Pressure (MPa)

		Max.cont.				Max.int.		
		4	8	10	12	16	20	24
Flow (L/min)	10	184 30	363 29	453 28	545 27	734 26	891 25	1062 23
	20	189 60	380 59	472 58	562 56	757 54	917 52	1109 50
Max.cont.	40	191 121	381 120	484 118	570 115	774 112	954 109	1149 104
	60	189 183	376 181	493 179	573 175	772 172	962 168	1154 158
Max.int.	80	179 244	369 242	479 239	565 236	768 231	954 227	1153 217
	100	169 305	357 304	467 301	562 298	758 294	942 289	1143 276
	125	147 380	336 378	447 375	544 371	745 367	920 362	1127 349
	150	119 458	318 456	432 453	526 449	713 444	894 431	1097 425

Torque (N•m) 552
Speed (rpm) 572



Performance Data

BMT 400 [410.9cm³/rev.]

Pressure (MPa)

		Max.cont.					Max.int.	
		3	6	9	12	15	18	21
Flow (L/min)	10	176	367	560	715	885	1050	1209
		24	23	22	21	20	19	18
	20	179	370	565	726	899	1071	1236
		49	48	47	44	42	40	38
	40	176	370	567	733	919	1091	1263
		96	95	93	90	87	83	79
	60	174	361	563	729	920	1095	1269
	145	143	139	135	131	127	121	
80	166	353	553	719	912	1084	1263	
	193	191	188	184	180	176	170	
100	150	339	538	708	896	1067	1252	
	242	240	238	234	228	224	218	
Max.cont.	125	135	309	524	688	873	1045	1221
		302	300	298	294	289	285	278
Max.int.	150	126	292	508	666	852	1020	1197
		364	362	358	354	350	346	339

BMT 500 [523.6cm³/rev.]

Pressure (MPa)

		Max.cont.					Max.int.	
		3	6	9	12	14	16	18
Flow (L/min)	10	222	451	692	892	1050	1193	1340
		18	18	18	17	16	15	13
	20	231	464	714	918	1070	1220	1377
		37	36	35	34	33	32	30
	40	230	466	727	941	1094	1244	1422
		75	74	73	72	70	68	64
	60	225	457	714	941	1088	1245	1409
	113	112	111	109	107	105	101	
80	213	431	696	927	1076	1244	1401	
	151	150	149	147	145	143	138	
100	194	420	680	901	1063	1224	1383	
	189	188	187	185	183	181	177	
Max.cont.	125	182	398	641	877	1024	1199	1352
		237	236	235	233	231	229	225
Max.int.	150	147	369	618	853	1004	1167	1325
		284	283	282	280	278	276	272

BMT 630 [629.1cm³/rev.]

Pressure (MPa)

		Max.cont.					Max.int.	
		3	6	9	10.5	12	14	16
Flow (L/min)	10	233	520	795	902	1074	1194	1363
		14	14	13	13	13	11	11
	20	237	554	837	953	1117	1239	1407
		28	27	27	26	26	24	22
	40	239	553	860	987	1171	1308	1483
		62	62	61	60	59	56	54
	60	223	544	863	978	1172	1318	1498
	94	94	92	91	90	86	82	
80	220	537	854	965	1172	1314	1497	
	123	122	121	119	118	114	110	
100	208	522	832	945	1156	1303	1488	
	156	155	153	152	150	147	142	
Max.cont.	125	201	499	810	931	1137	1292	1472
		196	196	194	192	191	187	183
Max.int.	150	174	492	785	921	1121	1277	1454
		233	232	231	230	227	223	217

BMT 800 [801.8cm³/rev.]

Pressure (MPa)

		Max.cont.					Max.int.
		3	6	9	10.5	12.5	13
Flow (L/min)	10	346	677	1003	1159	1365	1390
		12	12	11	11	11	10
	20	356	692	1034	1183	1404	1458
		24	24	24	23	22	18
	40	365	703	1066	1236	1459	1516
		50	50	49	48	46	40
	60	354	703	1060	1237	1464	1520
	74	73	71	71	68	63	
80	332	686	1050	1226	1464	1514	
	99	98	98	96	93	86	
100	305	654	1025	1207	1445	1506	
	125	123	123	121	118	110	
Max.cont.	125	280	622	989	1181	1422	1487
		154	153	153	150	149	140
Max.int.	150	247	590	953	1156	1406	1476
		185	184	183	181	179	172

Torque (N•m) 1121
Speed (rpm) 227

BMT Dimensions & Mounting Data

Model	L	L1	L2
BMT-160-W	127	17	77
BMT-200-W	131	21	81
BMT-250-W	136	14	86
BMT-315-W	142	20	91
BMT-400-W	148	27	98
BMT-500-W	157	35	106
BMT-630-W	169	47	118
BMT-800-W	180	58	129

BMT Porting

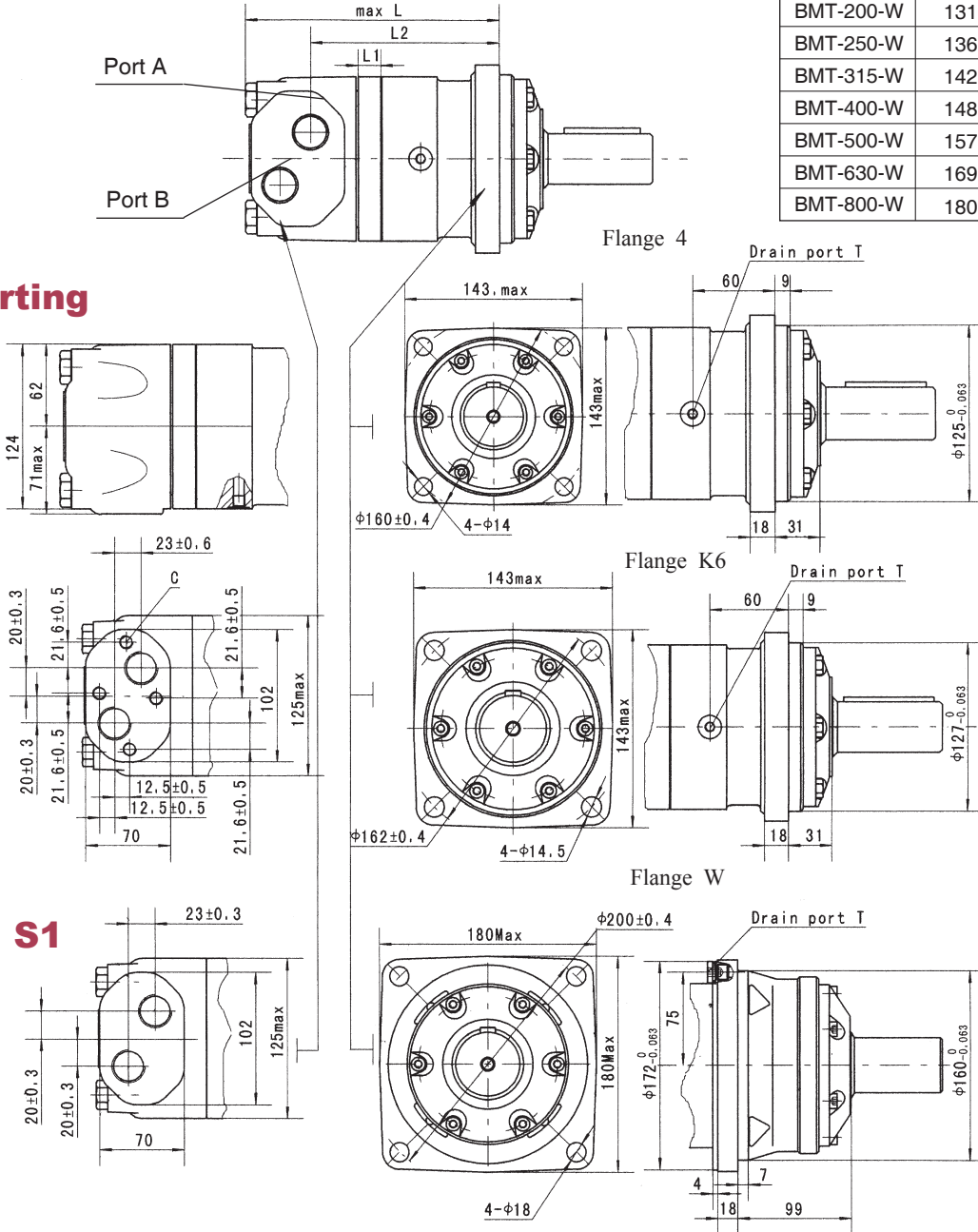

BMT Mounting Flange

4

European version

**Pilot Dia: 125 mm
Bolt Circle: 160 mm**

K6

SAE C 4-Bolt

**Pilot Dia: 127mm (5")
Bolt Circle: 161.9mm (6.375")**

W

Wheel Mount

**Pilot Dia: 160 mm
Bolt Circle: 200 mm**

D, M

S, G, M3, S1

Model	L	L1	L2
BMT160	193	17	142.5
BMT200	197	21	146.5
BMT250	204	14	152.5
BMT315	210	20	158.5
BMT400	217	27	165.5
BMT500	225	35	173.5
BMT630	237	47	185.5
BMT800	248	58	196.5

Content	Code					
	D (depth)	M (depth)	S (depth)	G (depth)	M3 (depth)	S1 (depth)
P(A,B)	G3/4 (18)	M27 x 2 (18)	1-1/16-12UN (18)	G3/4 (18)	M27 x 2 (18)	1-1/16-12UN (18)
T	G1/4 (12)	M14 x 1.5 (12)	9/16-18UNF (12)	G1/4 (12)	M14 x 1.5 (12)	7/16-20UNF (12)
C	4-M10(10)	4-M10(10)	--	--	--	--

Note: 1) The thickness of the stator and rotor for disp. from 160 to 200 is the dimension of L1 adding on 3mm.
2) The thickness of the stator and rotor for disp. from 250 to 800 is the dimension of L1 adding on 7mm.

BMTE Dimensions & Mounting Data

**BMTE Porting
SF5, SF6, SF7**

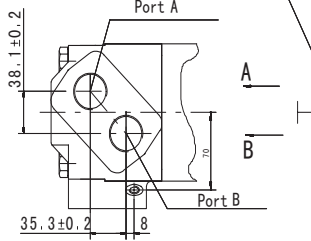
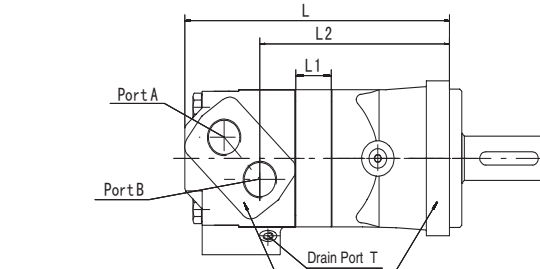

SF

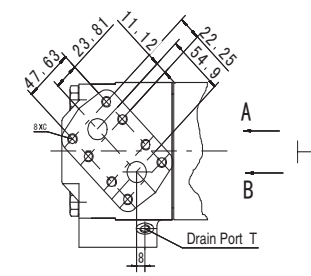

SE, SE1, SE2

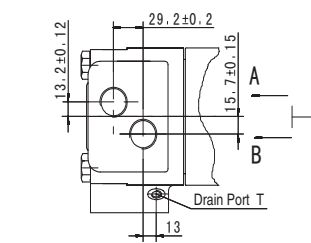

**BMTE
Mounting
Flanges**

CC

**SAE C 4-Bolt
Pilot Dia:
127mm (5")
Bolt Circle:
161.9mm (6.375")**

Flange CC

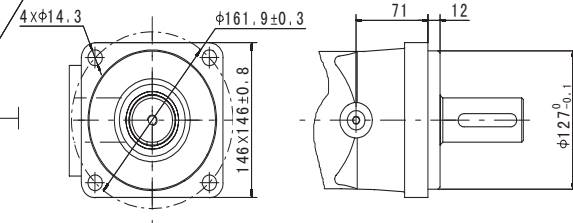

WE

**Wheel Mount
Pilot Dia:
127 mm (5")
Bolt Circle:
147.6 mm (5.813")**

Flange WE

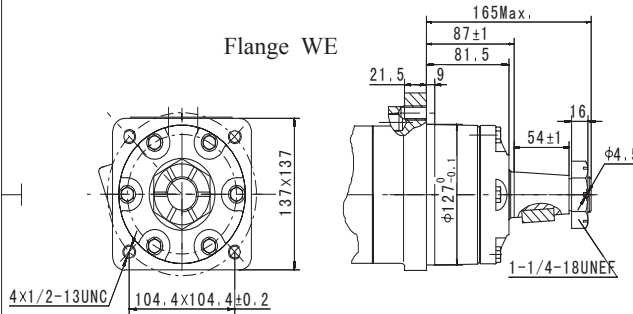

B2E

**SAE B 4-Bolt
Pilot Dia:
101.6 mm (4")
Bolt Circle:
127 mm (5")**

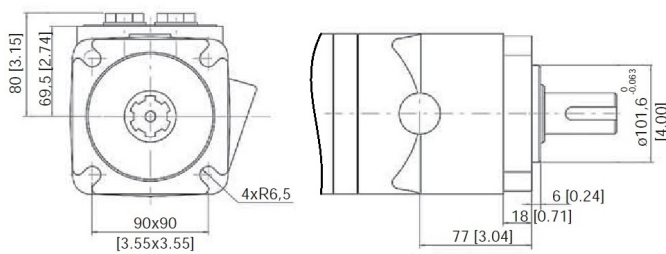

Model	L	L1	L2
BMTE230	238.5	12	164.5
BMTE250	240.5	14	166.5
BMTE315	246.5	20	172.5
BMTE400	253.5	27	179.5
BMTE500	261.5	35	187.5
BMTE630	273.5	47	199.5
BMTE800	284.5	58	210.5

Note:1)The data for the port of SF (SF5 and SF6and sf7)
2)The data for the port of SE (SE1 and SE2) and flange WE:L-70 and L2-59.
3)The thickness of the stator and rotor for disp,from 315 to 800 is the dimension of L1 adding on 7mm.

Content	Code						
	SF5(depth)	SF6 (depth)	SF7 (depth)	SF (depth)	SE (depth)	SE1 (depth)	SE2(depth)
P(A,B)	1-5/16-12UN (18)	M33 x 2 (18)	G1 (18)	3/4" (18)	1-1/16-12UN (18)	1-1/16-12UN (18)	G3/4 (18)
T	7/16-20UNF (12)	M14 x 1.5 (12)	G1/4 (12)	7/16-20UNF (12)	9/16-18UNF (12)	7/16-20UNF (12)	G1/4 (12)
C	--	--	--	8 x 3/8-16UNC	--	--	--

BMTS (bearingless) Dimensions & Mounting Data

(BMTS models are offered from 230 cc/rev and upwards)

BMTS Porting

D, M

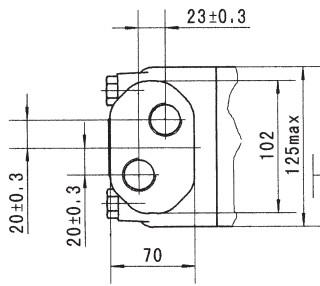
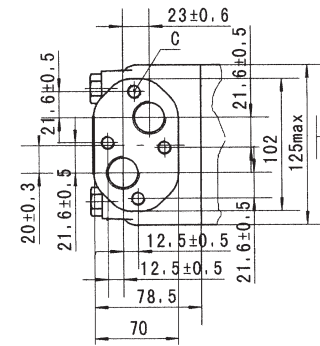
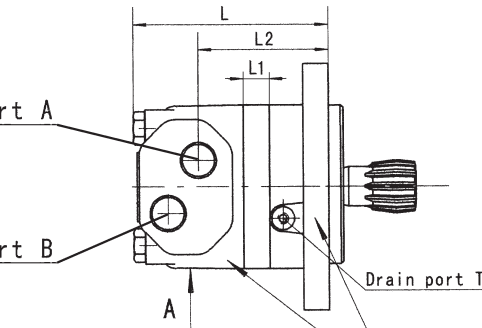

S, G, M3, S1

BMTS Mounting Flanges

D

European version

Pilot Dia:
125mm
Bolt Circle:
160mm

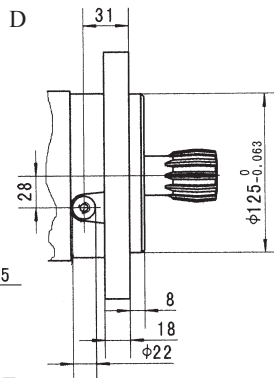
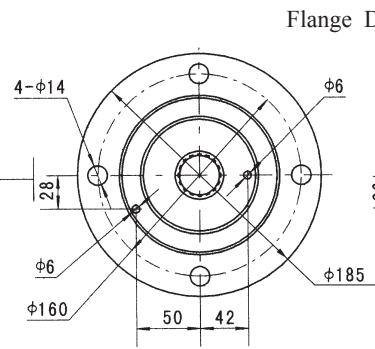
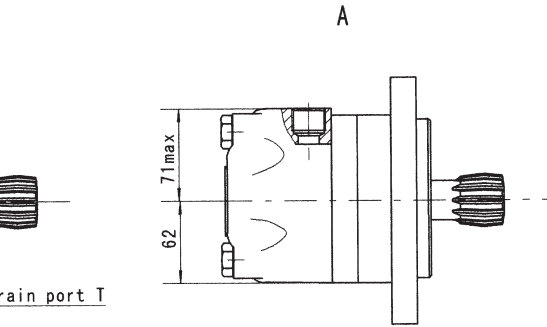

E

SAE C 4-Bolt

Pilot Dia:
127mm (5")
Bolt Circle:
161.9mm (6.375")

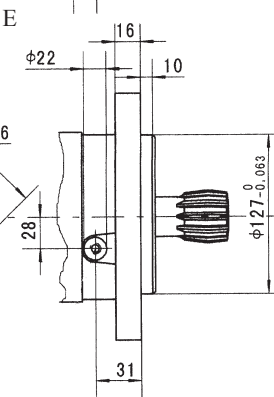
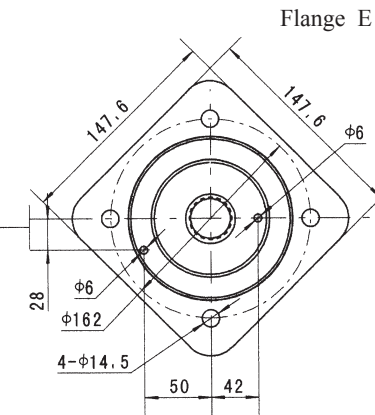

Model	L	L1	L2
BMT160	148	17	96.5
BMT200	152	21	100.5
BMT250	157	14	109
BMT315	163	20	115
BMT400	170	27	122
BMT500	178	35	130
BMT630	190	47	142
BMT800	201	58	153

Content	Code					
	D (depth)	M (depth)	S (depth)	G (depth)	M3 (depth)	S1 (depth)
Mounting P(A,B)	G3/4 (18)	M27 x 2 (18)	1-1/16-12UN (18)	G3/4 (18)	M27 x 2 (18)	1-1/16-12UN (18)
T	G1/4 (12)	M14 x 1.5 (12)	9/16-18UNF (12)	G1/4 (12)	M14 x 1.5 (12)	7/16-20UNF (12)
C	4-M10(10)	4-M10(10)	--	--	--	--

Note: 1) The thickness of the stator and rotor for disp. from 160 to 200 is the dimension of L1 adding on 3mm.
2) The thickness of the stator and rotor for disp. from 250 to 800 is the dimension of L1 adding on 7mm.

BMTS (Bearingless)

DIMENSIONS OF THE ATTACHED COMPONENT

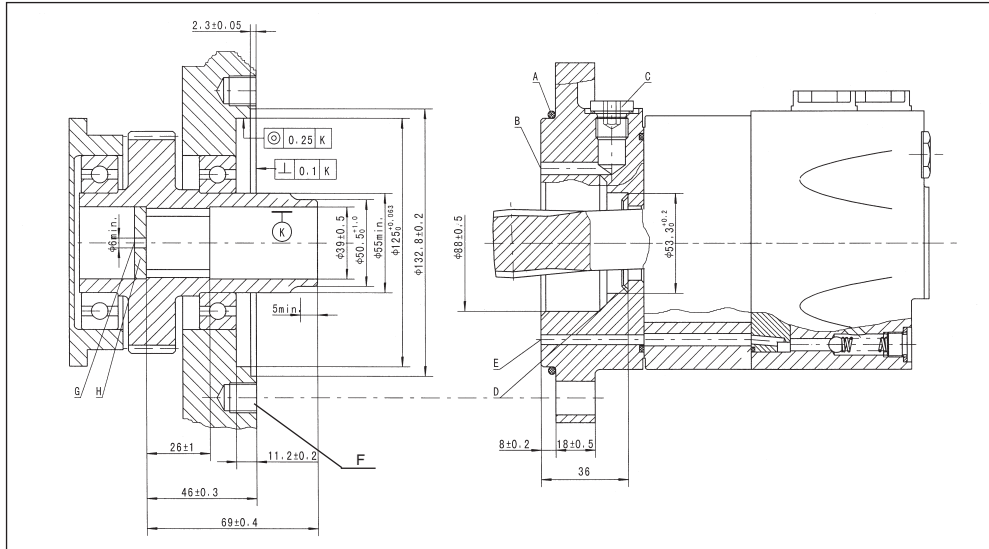

- A: O-ring:125x3
- B: External drain channel
- C: Drain connection G 1/4;12 mm deep
- D: Conical seal ring
- E: Internal drain channel
- F: M12;min. 18mm deep
- G: Oil circulation hole
- H: Hardened stop plate

Internal Spline Data For The Attached Component

Fillet Root Side Fit		mm
Number of Teeth	Z	16
Diametral Pitch	DP	12/24
Pressure Angle	α_D	30°
Pitch Dia.	D	ø33.8656
Major Dia.	D_{ei}	ø38.4 ^{+0.25} ₀
Minor Dia.	D_i	ø32.15 ^{+0.04} ₀
Space Width [Circular]	E	4.516±0.037

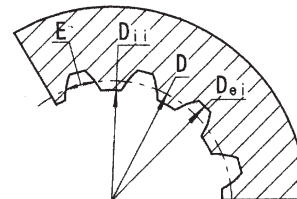

Hardening Specification: HRC 62±2
Effective case depth 0.7±0.2

BMTJ Dimensions & Mounting Data

BMTJ Porting SF5, SF6, SF7

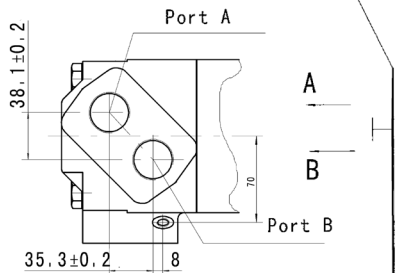
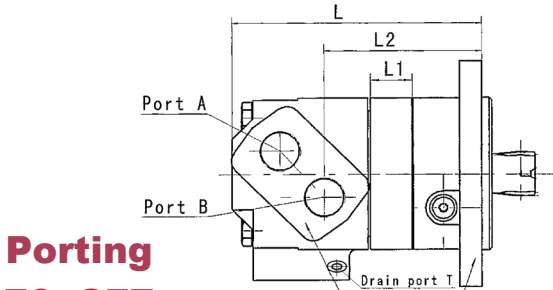

SF

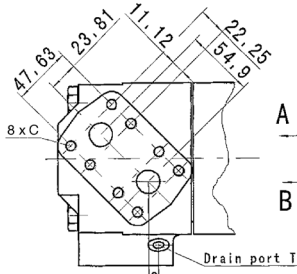

SE, SE1, SE2

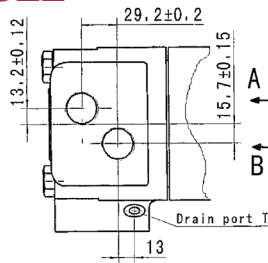

BMTS Mounting Flanges

J

SAE C 4-Bolt
Pilot Dia:
127mm (5")
Bolt Circle:
161.9mm (6.375")

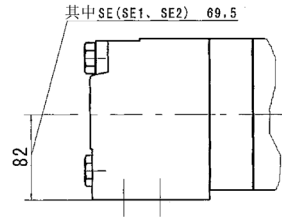

Flange J

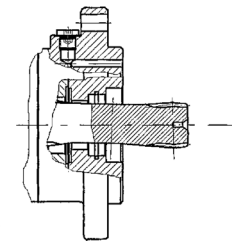
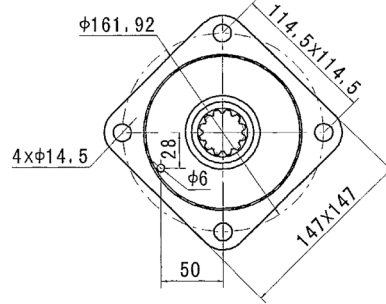
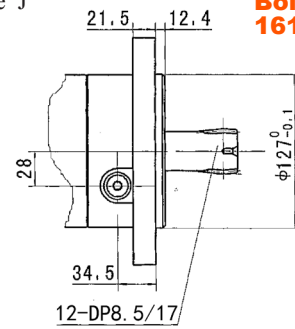

Model	L	L1	L2
BMTJ230	176	12	104.5
BMTJ250	178	14	106.5
BMTJ315	184	20	112.5
BMTJ400	191	27	119.5
BMTJ500	199	35	127.5
BMTJ630	211	47	139.5
BMTJ800	222	58	150.5

Note: 1) The data for the port of SF (SF5 and SF6 and SF7).
 2) The data for the port of SE (SE1 and SE2) and flange WE: L-70 and L2-59.
 3) The thickness of the stator and rotor is the dimension of L1 adding on 7mm.

Content	Code						
	SF5 (depth)	SF6 (depth)	SF7 (depth)	SF (depth)	SE (depth)	SE1 (depth)	SE2 (depth)
P(A,B)	1-5/16-12UN (18)	M33 x 2 (18)	G1 (18)	3/4" (18)	1-1/16-12UN (18)	1-1/16-12UN (18)	G3/4 (18)
T	7/16-20UNF (12)	M14 x 1.5 (12)	G1/4 (12)	7/16-20UNF (12)	9/16-18UNF (12)	7/16-20UNF (12)	G1/4 (12)
C	--	--	--	8 x 3/8-16UNC	--	--	--

BMTJ Dimensions & Mounting Data

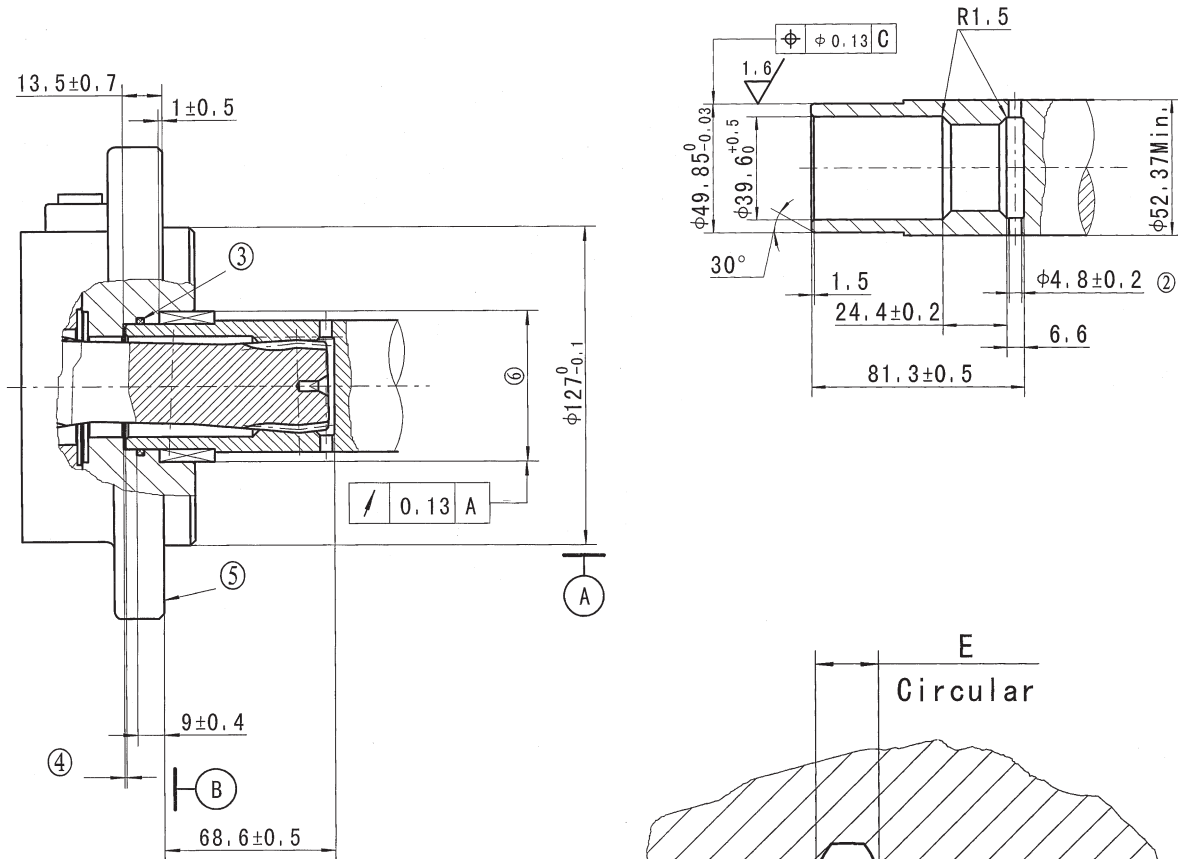

Internal Spline Data For The Attached Component

Fillet Root Side Fit		mm
Number of Teeth	Z	12
Diametral Pitch	DP	8.5/17
Pressure Angle	D	30°
Pitch Dia.	α_D	$\phi 35.858823$
Major Dia.	D_{ei}	$\phi 38.97^{+0.20}_0$
Minor Dia.	D_i	$\phi 33.3^{+0.18}_0$
Space Width [Circular]	E	5.866 ± 0.032
Dimension between two pins ($\phi 4$)	M_e	$26.929-27.084$

① Internal spline in mating part to be as follows: Material to be ASTM A304, 8620H. Carborize to a hardness of 60-64HRC with case depth (to 50HRC) of 0.75-1 [.030-.040] (dimensions apply after heat treat).

② Mating part to have critical dimensions as shown, Oil holes must be provided and open for proper oil circulation.

③ Some means of maintaining clearance between shaft and mounting flange must be provided.

④ Seal to be furnished with motor for proper oil circulation thru splines.

⑤ Similar to SAE "C" Four Bolt Flange

⑥ Counterbore designed to adapt to a standard sleeve bearing 50.010-50.038 [1.9689-1.9700] ID by 60.51-60.079 [2.3642-2.3653] O.D. (Oilite bronze sleeve bearing).

C This surface to be diameter of output shaft.

BMT(E) Shaft Extensions & Dimensions

BMT(E) SHAFT M

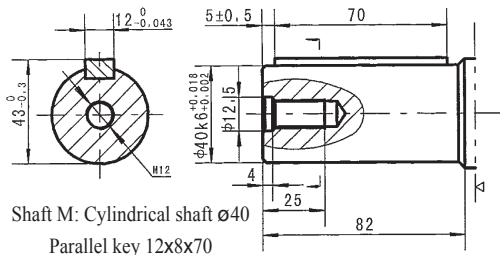

BMT(E) SHAFT G1

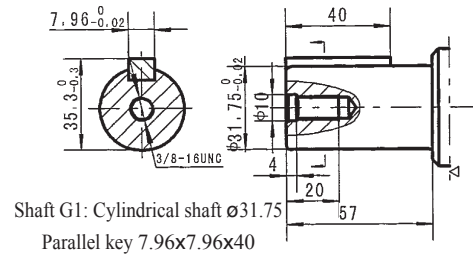

BMT(E) SHAFT G

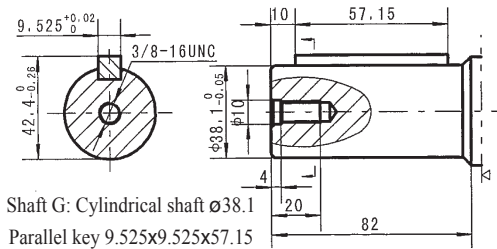

BMT(E) SHAFT F1

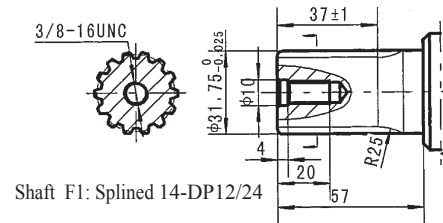

BMT(E) SHAFT T

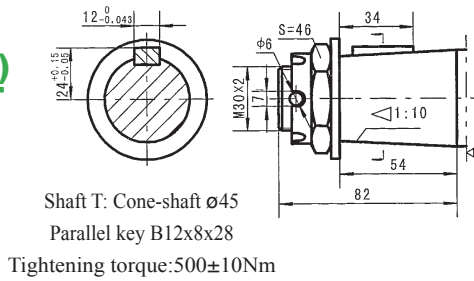

BMT(E) SHAFT T1

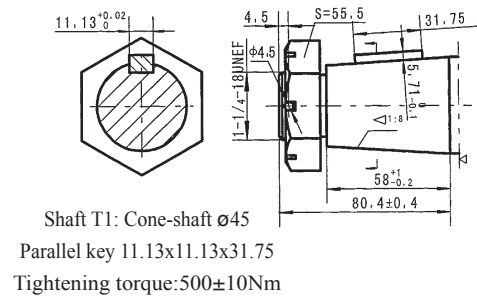

BMT(E) SHAFT FD

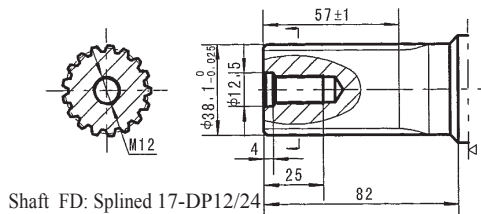

BMT(E) SHAFT F

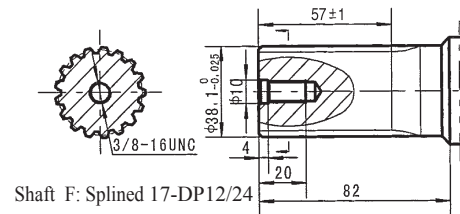

BMT(E) SHAFT SL

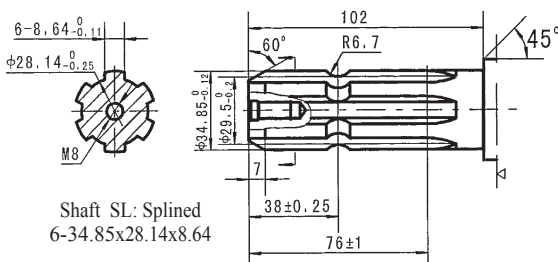

BMT(E) SHAFT Y1

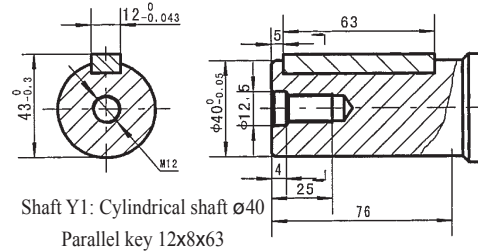

▷ Motor Mounting Surface

SHAFT EXTENSIONS FOR BMT(E) MOTORS

**BMT(E)
SHAFT
B**

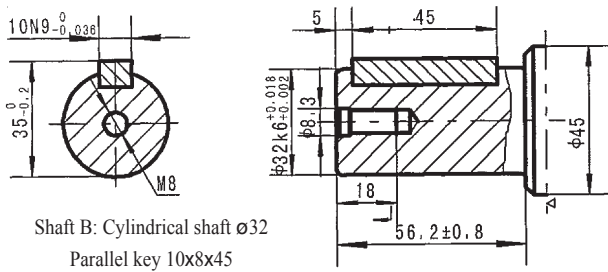

**BMT(E)
SHAFT
Y**

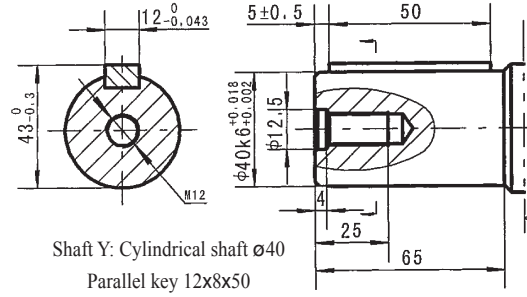

**BMT(E)
SHAFT
G2**

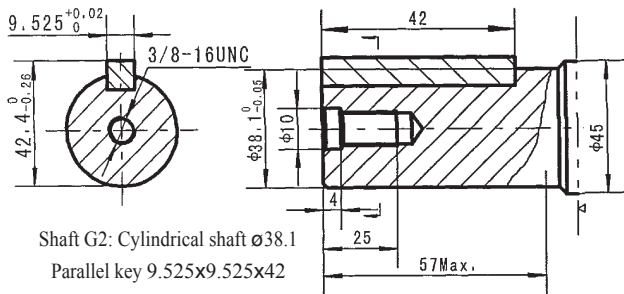

**BMT(E)
SHAFT
Y2**

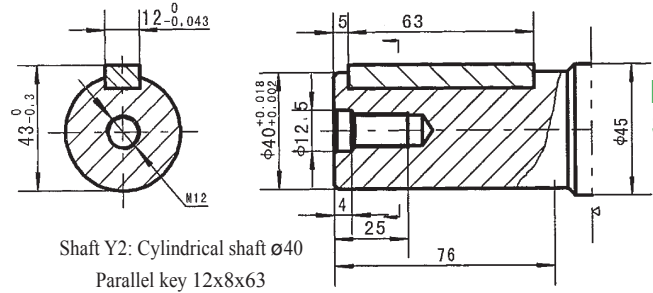

**BMT(E)
SHAFT
T2**

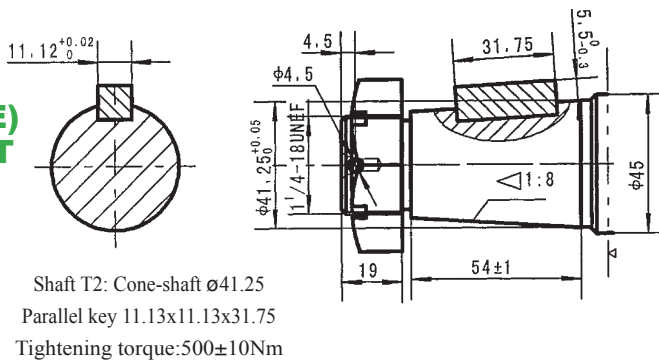

**BMT(E)
SHAFT
FE**

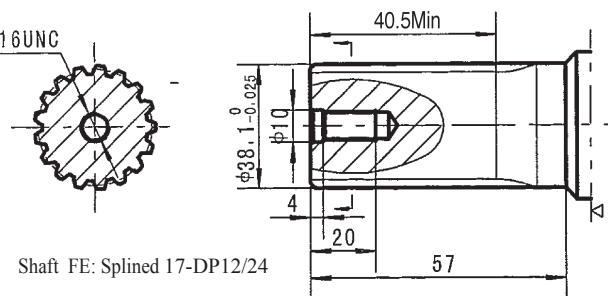

▷ Motor Mounting Surface

BMT Series Hydraulic motor

Schematic

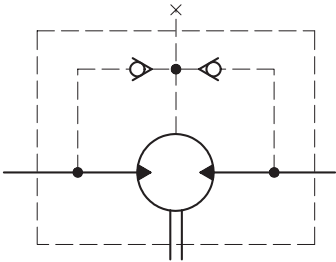

Permissible Shaft Seal Pressure

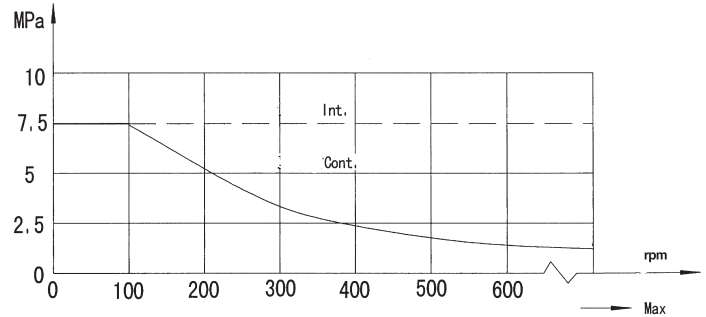

Direction of Shaft Rotation, Standard

When facing shaft end of motor, shaft to rotate:
 Clockwise when port "A" is pressurized.
 Counter-clockwise port "B" is pressurized.

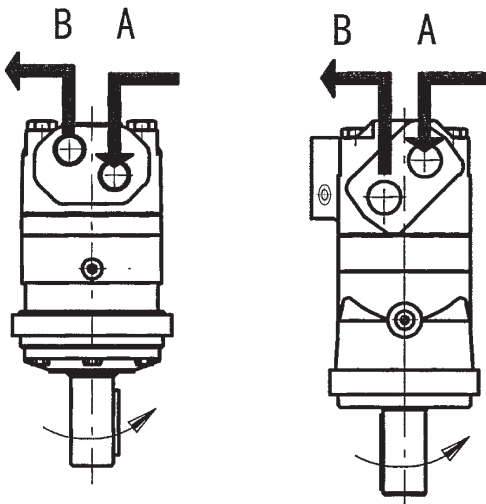

In applications without drain line, output shaft seal exceeds a bit of the pressure in the return line. When applications use the drain line, the pressure of output shaft seal equals the pressure in drain line.

Axial & Radial Forces

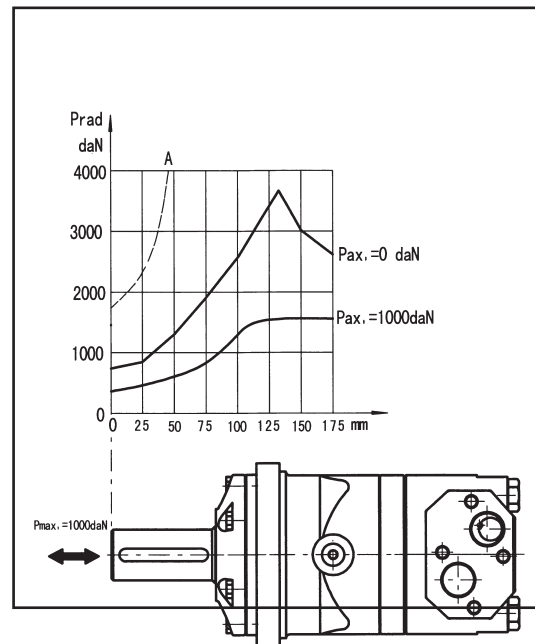

Oil Flow In Drain Line

The table shows the Max. oil flow in the drain line at a return pressure less than 0.5-1MPa.

Pressure drop (MPa)	Viscosity (mm ² /s)	Oil flow in the drain line (L/min.)
14	20	2.5
	35	1.5
21	20	5
	35	3

The output shaft runs in tapered bearings that permit high axial and radial forces, Curve "A" shows max radial shaft load, Any shaft loads exceeding the values quoted in the curve will involve a risk of breakage, The two other curves apply to a B10 bearing life of 3000 hours at 200 RPM.

Order Information

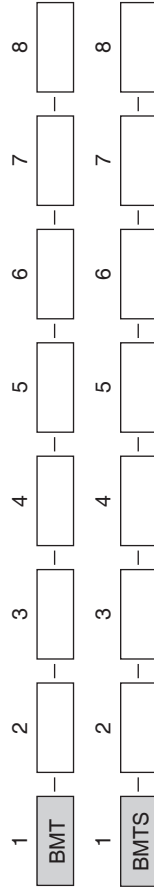

Pos.1	2	3	4	5	6	7	8
Code	Disp.	Flange	Output Shaft	Ports and Drain Port	Rotation Direction	Paint	Unusually Function
BMT	160	4 4-Ø14 Square-flangeØ160, pilotØ125 × 9 K6 4-Ø14.5Square-flangeØ162, pilotØ127 × 9 W 4-Ø18 Wheel-flangeØ200, pilotØ160 × 7	M Shaft Ø40 , parallel key 12 × 8 × 70	D G3/4 Manifold Mount, 4-M10 , G1/4 M M27 × 2 Manifold Mount, 4-M10, M14 × 1.5 S 1-1/16-12UN O-ring, 9/16-18UNF S1 1-1/16-12UN O-ring, 7/16-20UNF G G3/4, G1/4 M3 M27 × 2, M14 × 1.5	Omit Standard R Opposite	Omit Black Anfield Std	Omit Standard Free Running Low Speed
	200		G Shaft Ø38.1 ,parallel key 9.52 × 9.52 × 57.15				
	250		F Shaft Ø38.1 ,splined tooth 17-DP12/24				
	315		FD Shaft Ø38.1 ,splined tooth 17-DP12/24				
	400		T Cone-shaft 1:10 Ø45 ,parallel key B12 × 8 × 28				
	500		T1 parallel key 11.13 × 11.13 × 31.75				
	630		SL shaft Ø34.85, Splined key				
	800		G1 Splined key 6-34.85 × 28.14 × 8.64				
			F1 shaftØ31.75 , parallel key 7.96 × 7.96 × 40				
			F1 Shaft Ø31.75, splined tooth 14-DP12/24				
BMTS		D 4-Ø14 Circle-flange Ø160, pilot Ø125 × 8	Omit				
		E 4-Ø14.5 Square-flange Ø162, pilot Ø127 × 10	Short shaft 16-DP12/24				

Order Information

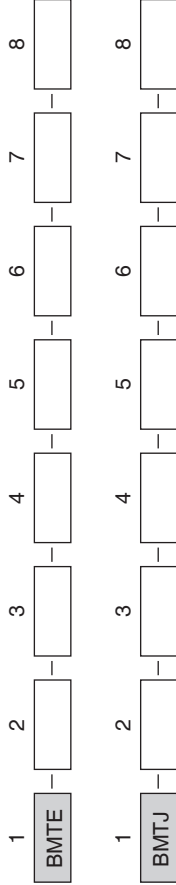

Pos.1	2	3	4	5	6	7	8
Code	Disp.	Flange	Output Shaft	Ports and Drain Port	Rotation Direction	Paint	Unusually Function
BMTE	230	CC SAE C 4-BOLT pilot Ø127×12 4-Ø14.3 Square-flange Ø161.9,	G2 Shaft Ø38.1 ,parallel key 9.52 × 9.52 × 42	SF 3/4" ,Manifold Mount,8-3/8-16UNC, 7/16-20UNF SF5 1-5/16-12UN O-ring,7/16-20 UNF SF6 M33 × 2,M14 × 1.5 SF7 G1,G1/4 SE 1-1/16-12UN O-ring,9/16-18UNF SE1 1-1/16-12UN O-ring,7/16-20 UNF SE2 G3/4,G1/4	Omit R	Omit Black Anfield Std	Omit Standard Free Running Low Speed
	250		FE Shaft Ø38.1 ,splined tooth 17-DP12/24				
	315	Y1 ShaftØ40,parallel key 12 × 8 × 63					
	400	Y2 ShaftØ40,parallel key 12 × 8 × 63					
	500	T2 Cone-shaft 1:8 Ø41.25 , parallel key 11.13 × 11.13 × 31.75					
	630	T3 Cone-shaft 1:8 Ø41.25 , parallel key 11.13 × 11.13 × 31.75					
BMTJ		J 4-Ø14.5 Square-flange Ø161.9 pilot Ø127 × 12.4	Omit Short shaft 12-DP8.5/17				

Note:When the table is used, please fill the code of left rows in the table and give us, which the code information is consists of construction, displacement, mounting flange, output shaft and ports . If the specification is not in the table or you have specific requirements, please contact Anfield .